



MLED-180HI Ex

External Powered Marine Lantern

MLED-180HI Ex brings the benefits of LED technology, low power, high reliability and low maintenance, to the Zone 1 environment. The flasher and optical source assembly designated MaxiHALO-180HI is designed after the proven MaxiHALO-150.

The MaxiHALO-180HI is installed in a rugged Exd well glass housing used in the rigours of offshore atmospheres. When used in a biform arrangement a range of in excess of 15NM is achieved. Onboard software constantly monitors operation of the MLED-180HI Ex and initiates an alarm signal if critical operation parameters are exceeded.

FEATURES

- User selectable power settings
- 256 user selectable flash characters
- Temperature compensated LED drive circuits ensure uniform brightness with changes in ambient temperature
- Full monitor and control capability
- Fail output terminal for go/no go monitoring
- Constant current power source maximises LED life

MLED-180HI Ex



SPECIFICATIONS

Input Voltage	24VDC
Average Power Consumption	<40W
Quiescent Current	<7mA
Visibility	360° horizon (omnidirectional)
Monitor and Control	Capable
Flash Codes	256 codes
Synchronisation	Hardwire
Sunswitch Threshold	Variable
Weight	15kg (33lb)
Operating Temperature	-40° C to +60° C
Relative Humidity	100% Condensing
Atmosphere	Rated for operation in salt air
Wind	Designed to withstand speeds in excess of 320kmph (200mph)
IP Rating	IP66
Protection	IIC GD EEx de IIC T3
Base	Cast Aluminium
Outer Lens	Tempered Glass

NOTE: Specifications are subject to change.

MLED-180HI Ex MEETS THE STRICT REQUIREMENTS OF THE NORTH SEA PLATFORMS

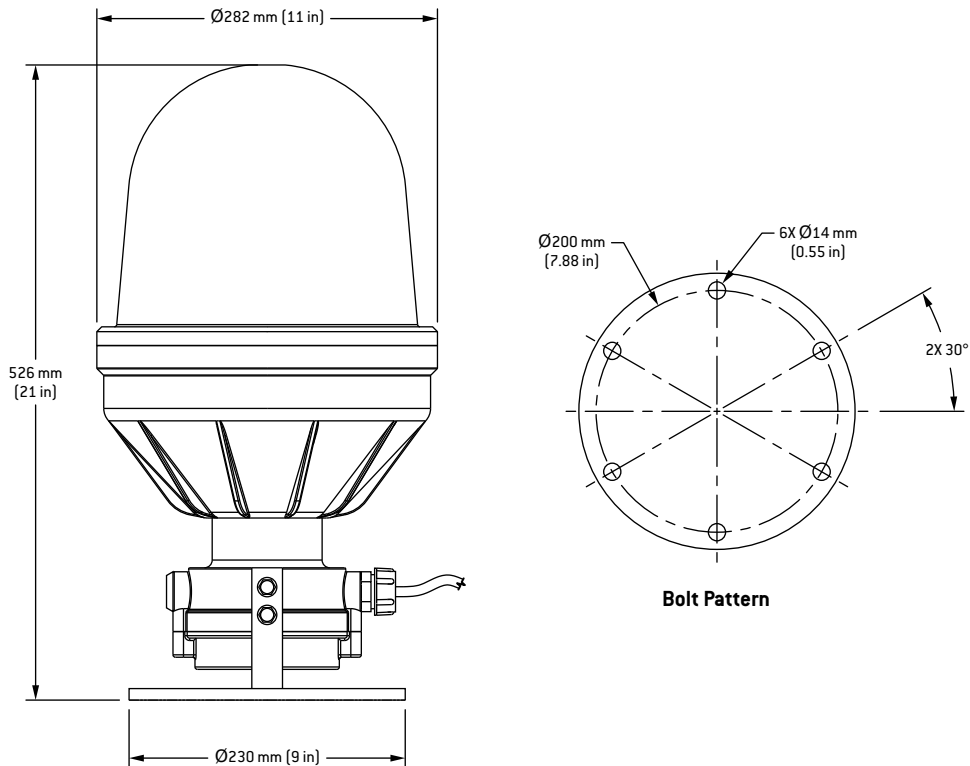

USA - HOUSTON
P: + 1 713 681 6101
F: + 1 713 681 6233
E: us-sales@tidelandsignal.com

CANADA - DSS MARINE
P: + 844 843 3526
F: + 613 680 7418
E: canada-sales@tidelandsignal.com

UK - BURGESS HILL
P: + 44 (0) 1444 872240
F: + 44 (0) 1444 872241
E: emea-sales@tidelandsignal.com

UK - GT YARMOUTH
P: + 44 (0) 1493 441711
F: + 44 (0) 1493 440322
E: emea-sales@tidelandsignal.com

UAE - DUBAI
P: + 971 (0) 4 885 5842
F: + 971 (0) 4 885 7352
E: emea-sales@tidelandsignal.com

SINGAPORE
P: + 65 6333 0078
F: + 65 6333 0079
E: asia-sales@tidelandsignal.com

CHINA
P: + 86 (0) 1380 101 4639
F: + 86 (0) 21 3868 8087
E: asia-sales@tidelandsignal.com